



19 Series Tightening Tools For Aerospace

January 2015

Product Overview



Accuracy

Lower Cost of Quality

- Industry-leading accuracy reduces costly rework
- Longer time between calibrations

Durability

Lower Cost of Operation

- Designed and tested to over 1 million cycles
- 5-year clutch warranty

Customizability

Higher Productivity

- Torque multiplier compatibility for large structure joints
- Specialty head compatibility for access limited applications
- Over 100 variations, including custom-built configurations

Ergonomics

Higher Productivity

- World-class ergonomics and comfort

19 Series



At Cleco, we meet the most stringent requirements of our aerospace customers. Developed over a 3 year span, we created a family of products that achieves unmatched torque capability, calibration cycle, ergonomics, and ease-of-repair.

When accuracy, repeatability, durability, and operator comfort matters the most, count on the 19 Series.

19 Series



- Powertrain

- Clecomatic® Clutch

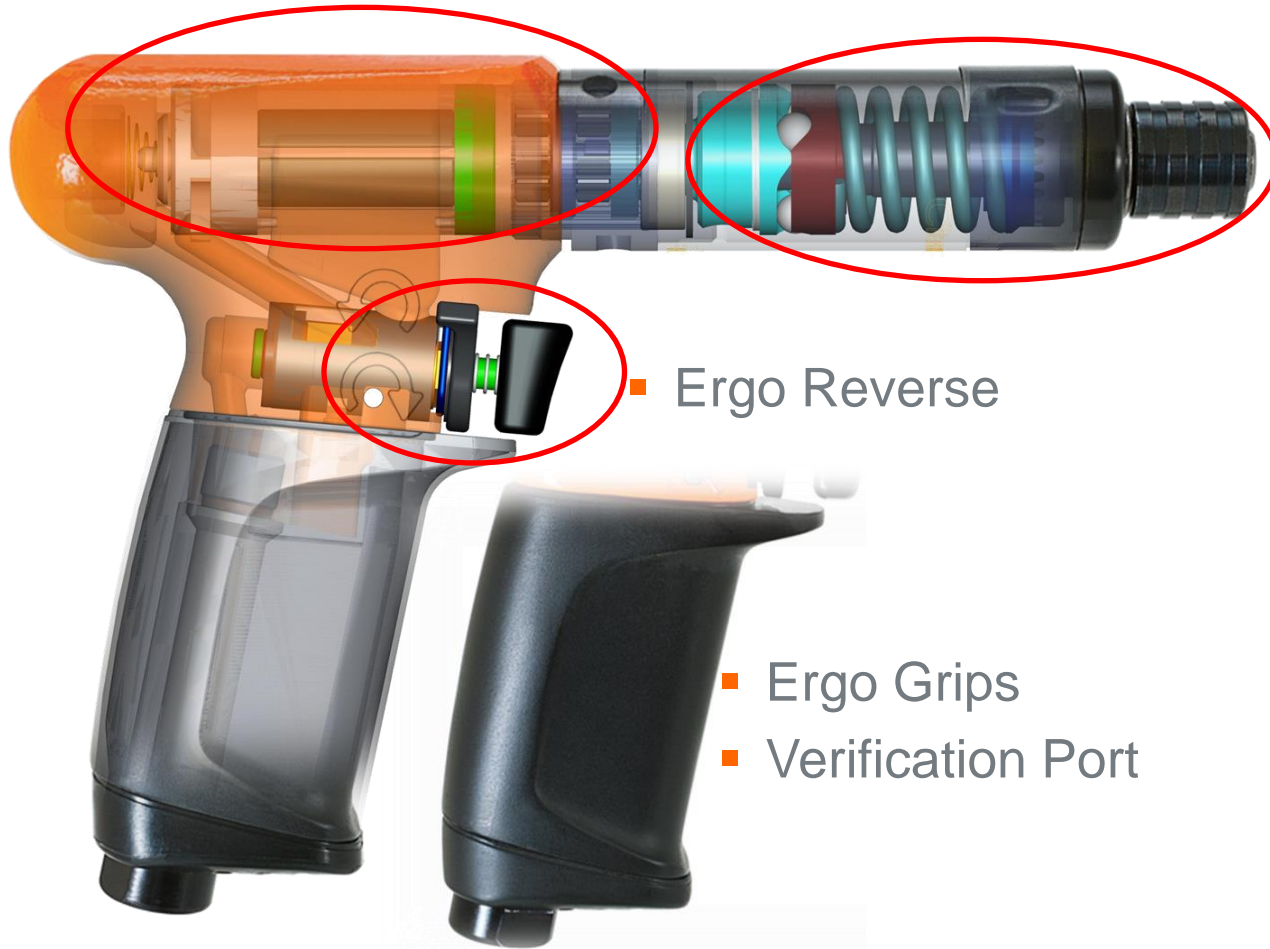

- Ergo Reverse

- Ergo Grips

- Verification Port

Clecomatic® Clutch - Accuracy and Repeatability

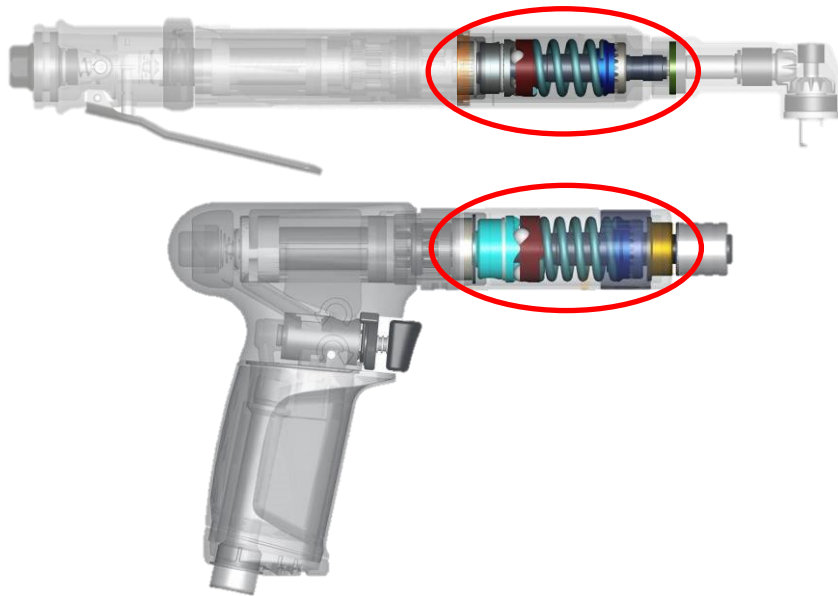

- Industry leading accuracy
- Industry leading repeatability
- Less time between calibration
- Clutch 5 year warranty

19 Series Clecomatic® Clutch vs Competitor A

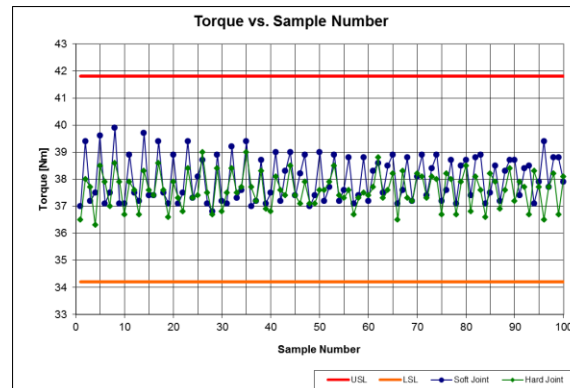
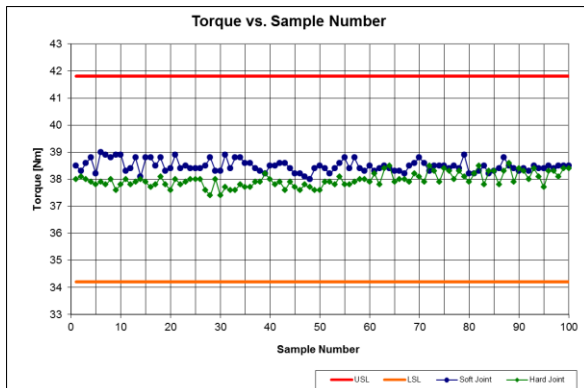

Power Train – Ergonomics and Spares Inventory



- Advanced material yield up to 50% weight reduction against competitor tools
- Common power train components across the range minimize spares requirement
- Efficient planetary design >95% maximizes torque output

Ergonomic Reverse, Grip Options and Torque Verification Port

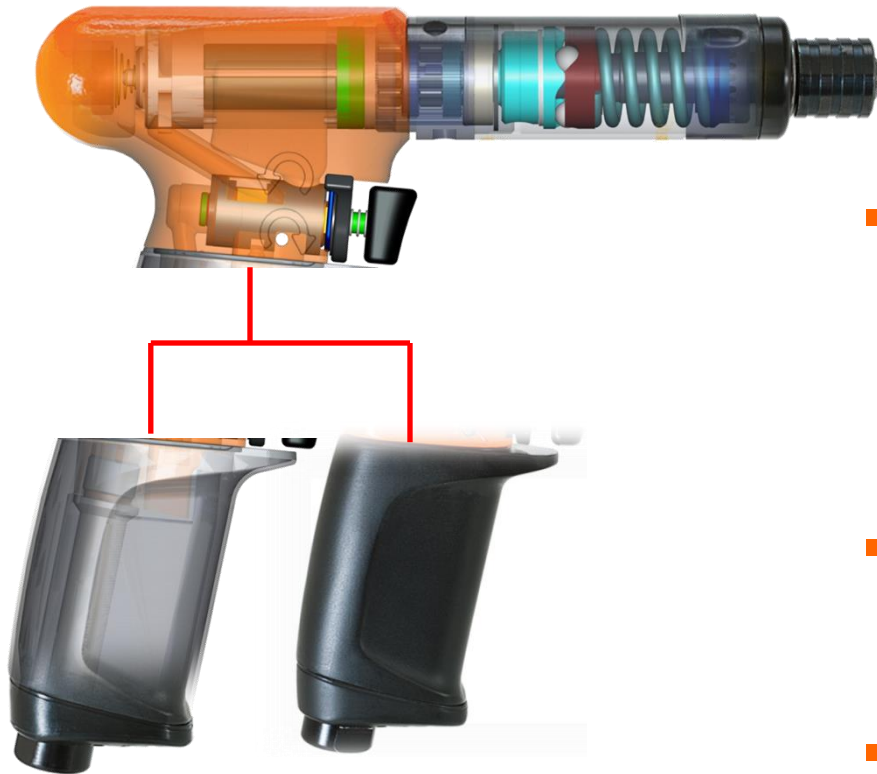

- Two interchangeable pistol grip handle sizes to customize to operator increasing operator comfort and productivity
- Soft-touch grip delivers superior protection against temperature, oil, grease, vibration, and slip meaning improved ergonomics and reduced fatigue
- Adjustable reverse lever offers true one-hand operation and adaptability for left-or-right-handed users
- Easy access torque verification port parallel to the main air line for streamlined hose management



VS



Industry-leading accuracy and repeatability	✓	
5 year warranty on auto shut-off clutch	✓	
Torque verification port as standard	✓	
2 Interchangeable handle sizes to provide comfort to a range of users	✓	
Torque Multiplier Compatibility	✓	
Over 100 variations offered, based on configuration, RPM, and torque range	✓	✓
Innovative materials yield one of the lightest weight tools on the market	✓	✓



- Nose
- Fuselage
- Wings and Wingbox



- Shells
- Panels
- Tail



- Frangible Fasteners



- Eddie Bolts



- Non Frangible Fasteners



- Temporary Fasteners



Cost of Quality

- Reduction in calibration cycles – a typical calibration cost is ~\$250
- Industry-leading accuracy reduces costly rework - typical cost of rework is ~ \$1000

Cost of Operation





- Designed and tested to over 1 million cycles to give less downtime and longer overall life
- Downtime can cost > \$100hr
- A year of life can be > \$200

Higher Productivity

- Whether it be from the advanced ergonomics or customized solution to optimize the working environment a 10% increase in productivity can be > \$100 per week per tool

Configurations & Options



Configuration	Shut Off Types	Torque Range	Speed Range RPM	Options
"P" Handle 	Torque Control Stall	5 ~130 in-lb 0.6 ~ 14.7 Nm ~ 40 in-lb ~ 4.5 Nm	260 ~ 2800 1100 ~ 2800	Trigger/Push to Start Specialty Heads TVP Torque Verifier
"T" Handle 	Torque Control Stall	5 ~130 in-lb 0.6 ~ 14.7 Nm ~ 40 in-lb ~ 4.5 Nm	260 ~ 2800 1100 ~ 2800	Trigger/Push to Start Specialty Heads TVP Torque Verifier
Right Angle 	Torque Control Stall	5 ~100 in-lb 0.6 ~ 11.3 Nm ~ 55 in-lb ~ 6.2 Nm	260 ~ 2800 850 ~ 1700	Specialty Heads TVP Torque Verifier Torque Multiplier
In Line 	Torque Control	5 ~130 in-lb 0.6 ~ 14.7 Nm	260 ~ 2800	Push to Start Lever/Push to start Quick change/Bit & Finder TVP Torque Verifier

Specialty heads are commonly used for applications with access challenges. Integrated with the 19 series fastening tool, we provide **Complete Fastening Solutions** for your **Aerospace Applications**.

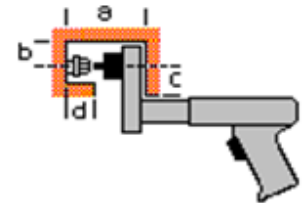
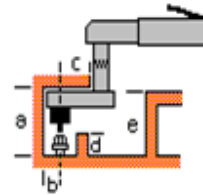
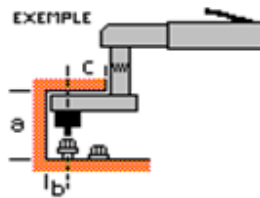
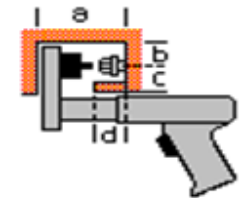
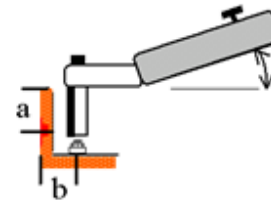
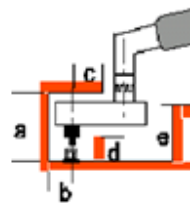

Products

Advanced Drilling

- Positive Feed
- Self Colleting

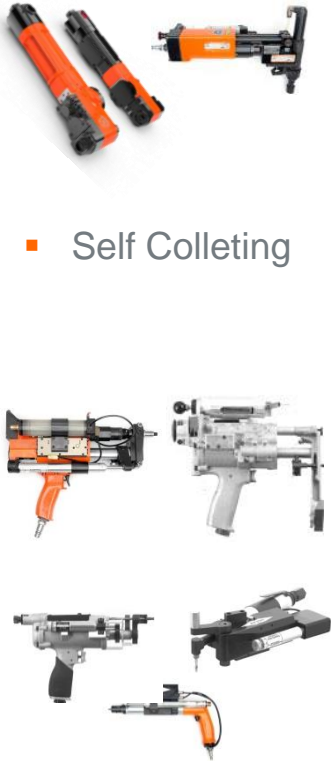

Specialty Cutters

- Drilling
- Countersinking (Manual)
- Drill and Countersink
- Reamers
- Back Spot Face

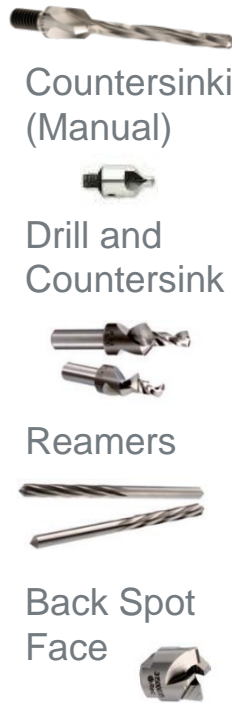

Tightening

- DC Electric Fastening
- Pneumatic Fastening
- Riveting
- Bits & Sockets

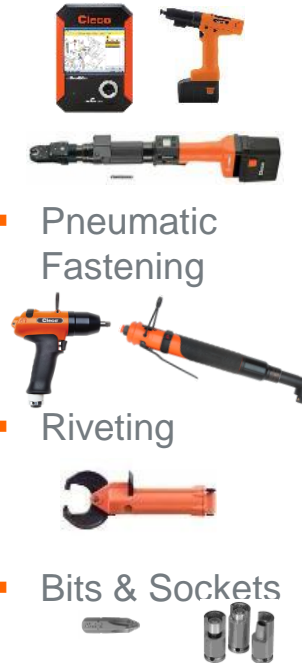

Material Removal

- Hand Drills & Microstop Cages
- Rivet Shavers
- Grinders
- Sanders

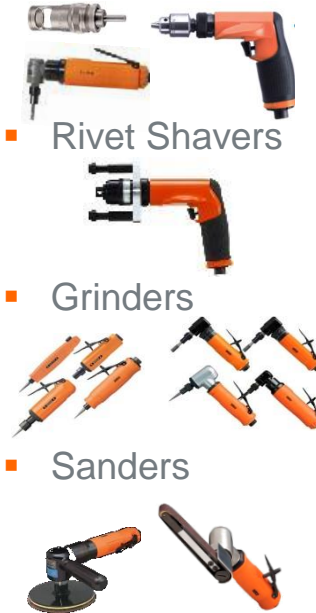

Universal Joints

- Universal Joints



APEX

Custom Solution/Service



Brands

Recoules Quackenbush

Recoules

Cleco
APEX

Recoules
DOTCO

Recoules Quackenbush
Cleco
DOTCO